

HAKKO BAKO^o

Operating Manual

Fermentation Chamber

HakkoBako Pro Gen1

HBP01



Table of Contents

1 Introduction 4

 1.1 Key Features 4

 1.2 Product Specifications 5

 1.3 General Regulations 6

2 Warning and Safety Information 7

 2.1 Warning & Safety Signs 7

 2.2 Important 7

 2.3 General Safety 8

 2.4 Warning and Safety Procedures 8

3 Installation 9

 3.1 Unpacking 9

 3.2 Placement 9

 3.3 Duck bill grommet 9

 3.4 Drip Pan 10

 3.5 Door Opener **Add-On** 10

 3.6 Wire Shelf and Shelf Brackets 10

 3.7 Electrical Connection 11

 3.8 Power On 11

4 Operation 12

 4.1 Setup the Chamber 12

 4.2 Start New Program 13

 4.2.1 Set Temperature 13

 4.2.2 Set Time 13

 4.2.3 Add and remove steps 14

 4.2.4 Save and Start 14

 4.2.5 Running 15

 4.3 Logs 16

 4.3.1 Autosaved Logs & My Logs 16

 4.3.2 Exporting Logs 16

 4.4 Program 17

 4.4.1 New Program 17

 4.4.2 Load Program 17

4.4.3 Edit and Save Program 17

5 Maintenance 18

5.1 Cleaning 18

5.2 Shut Down 19

5.3 Service and Parts Information..... 19

5.3.1 Spare Parts Availability 19

5.4 Troubleshooting 20

5.4.1 Error Code List 20

6 Transport and Handling 21

7 Limited Warranty..... 22

8 End-of-Life Disposal..... 23

1 Introduction

Welcome to the HakkoBako Pro Fermentation Chamber. Specifically designed for the needs of professional kitchens, this advanced chamber offers precise temperature control to create the perfect environment for various fermentation processes. With real-time humidity display, it allows chefs, bartenders and fermentation professionals to monitor conditions with ease, ensuring optimal results. Whether you're experimenting with new flavours or refining traditional techniques, HakkoBako provides the reliability and consistency needed to elevate your fermentation practices, all while handling the demands of a busy kitchen environment.

1.1 Key Features



Premium Stainless Steel

To protect the chamber from any acidic or corrosive ferments, high quality SUS304 is being used with an easy-to-clean surface finish.



Uniform Temperature Distribution

Powerful fans are used to create efficient internal cross flow air circulation. This allows uniform temperature distribution, from top to bottom of the chamber.



Easy Ferment

Easy to use software interface presented on a 10" full colour touch display that gives the ability to set multiple temperature and time steps, allowing fully customized fermentation programs and ensuring perfect results every time.



Fermentation Programs

Each fermentation program can be edited and saved. It also allows finetuning of temperature and time so you can develop the precise flavour and texture you seek with replicated outcome, with just a few clicks.



Food Safety Logs

HakkoBako Smart Logs offer comprehensive records and exportable history of your fermentations, making it essential for full traceability and maintaining compliance with food safety systems.



Auto-close door within 50°

Automatic door-closing design that allows easy access when loading and unloading your ferments.



Large Production Capacity

With a generous 440-liter storage capacity, the HakkoBako Pro Fermentation Chamber is designed to support substantial fermentation output, allowing your business to scale production while maintaining consistent, high-quality results



Water drainage

Smart water drainage system with easy to access drain pan makes cleaning and defrosting smooth and easy.

1.2 Product Specifications

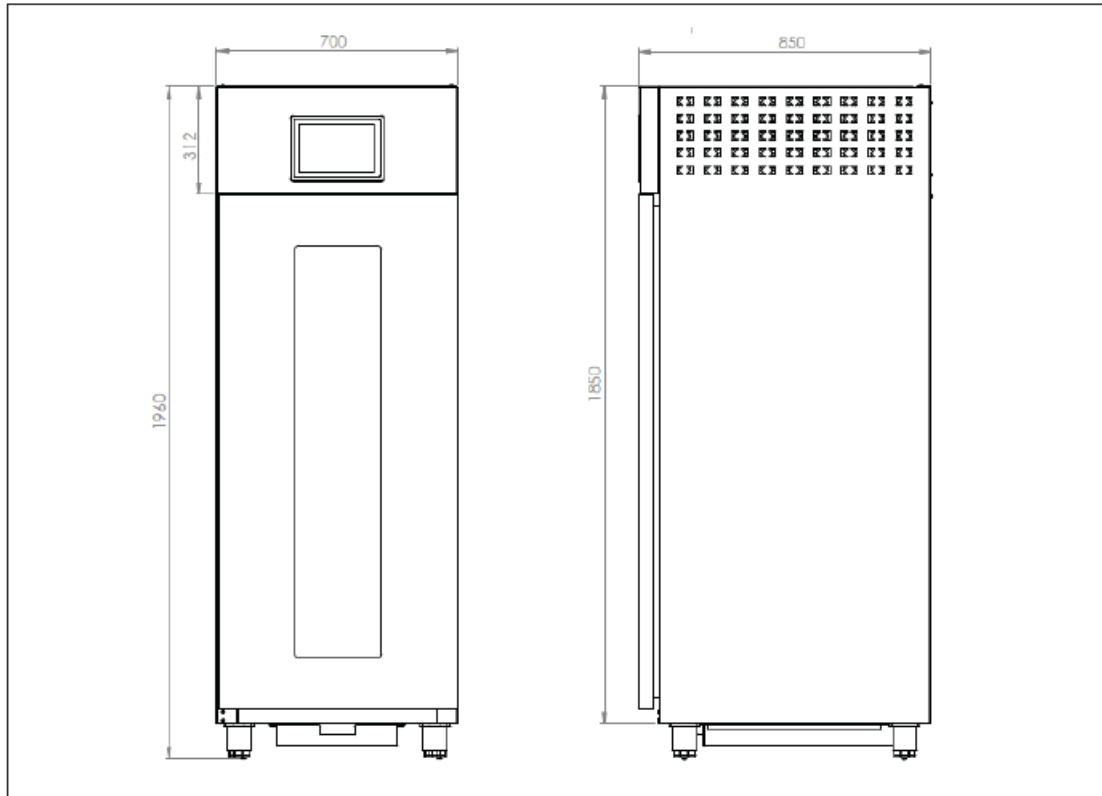

INTEGRATED SYSTEMS

- User Friendly Interface
- Fermentation Programs
- 10" LCD IPS Touch display
- IoT Connectivity
- Food Safety Logs (HACCP)
- Exportable Data Logs
- Internal Cross Flow Air Circulation
- Dimmable Chamber LED Lighting
- Heated Anti-Fog Window
- Heated Anti-Condensation Door Frame

PRODUCT SPECIFICATION

- Model number: HBP01
- Electricity rating: 220-240VAC 50/60Hz
- Heater power: 800W
- Cooling power: 540W
- Rack size: 530x530mm
- Inner dimensions: 580x570x1400mm
- Outer dimensions: 850x700x1960mm
- Gross weight: 140kg
- Temperature range: 2-60°C
- Humidity sensing: 0-100%RH
- Coolant: R134a
- Power Consumption 1 kW / 4.6A

1.3 General Regulations

Declaration of Conformity:



HakkoBako declares that all products manufactured by Hakko Bako Limited comply with the directives applicable to those products, and those products are therefore declared to be in conformity with the provisions of the legislation.

The data are reported on the product label placed on the back side of the fermentation chamber:

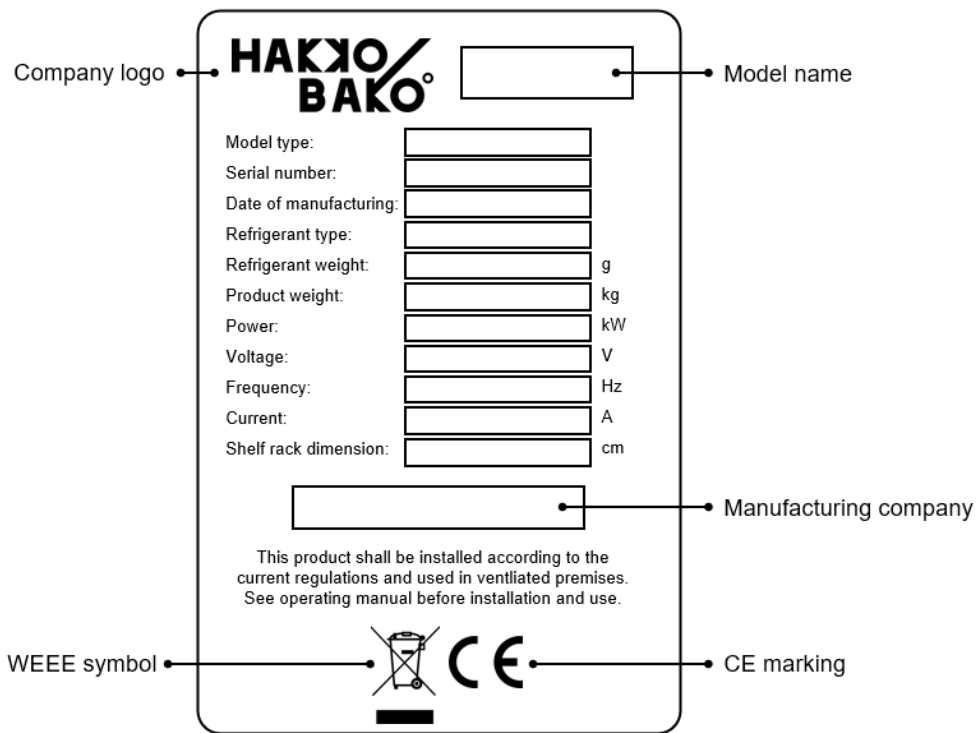

2 Warning and Safety Information

Thoroughly read and understand this manual before operating the chamber. Follow the instructions and warnings contained in this manual. It is the responsibility of the owner/operator of the chamber to train, supervise and authorize any person designated as an operator of this unit.

2.1 Warning & Safety Signs

To ensure safe use of the appliance and a proper understanding of the manual it is necessary to be familiar with the terms and typographical conventions used in the documentation. The following symbols are used in the manual to indicate and identify the various types of hazards:

**WARNING**

Danger for health and safety of operators.

**WARNING**

Risk of electric shock — dangerous voltage.

**CAUTION**

Beware of hot surfaces.

**CAUTION**

Risk of damage to the product.

**ATTENTION**

Important information on the product

2.2 Important

Important instructions and information about the device.

- Only specially trained personnel are authorized to make interventions on the device.
- The product is not intended for use by anyone with reduced physical, sensory, or mental capabilities, or by individuals with insufficient experience or knowledge, unless they are supervised or receive instructions on the use of the product from a person responsible for their safety.
- Children should be kept away from the chamber to prevent accidents and damage to the product.
- Keep all packaging materials and cleaning agents out of the reach of children.
- Do not place flammable, explosive, or volatile hazardous items, highly corrosive acids or alkalis, or liquids in glass containers in the chamber.
- Upon disposal of the device, the labelling must be destroyed.

2.3 General Safety

- The device is equipped with electrical and/or mechanical safety devices intended to protect personnel and the device itself.
- Any use of the chamber is prohibited when protective covers, guards, and safety devices are removed or when modifications have been made to the device.
- Do not make any changes to the parts that come with the product.
- Some illustrations in the manual show the device or parts of it without protection or with the protective covers removed. Such illustrations are for clarification purposes only. It is always prohibited to use the device without its protective covers or with safety devices disconnected.

2.4 Warning and Safety Procedures



Electrical Safety: Ensure the unit is properly grounded. Do not use extension cords or power strips which could potentially overload, unground or expose moisture to the electrical wiring.

The power supply system must be suitable for the device's rated current - the connection must be made in accordance with the safety regulations in the country of use. Information about the machine's voltage and frequency can be found on the product label. For the correct sizing of the switch or plug, refer to the device's data plate for details on power consumption.



Keep Dry: Do not wet this product or use it in potentially wet conditions. This may cause electrical leakage, resulting in electric shock or fire.



Location: Place the Fermentation chamber on a firm and flat ground foundation at indoor area. Allow at least 100 cm clearance at the front of the unit for smooth door operation.



Operating Temperature: The fermentation chamber has been designed and built to operate in optimal ambient conditions at temperatures of +10°C to +38°C, with adequate air circulation. The chamber should not be located outdoors, next to ovens, grills or other high heat producing equipment. In places with characteristics that are different from the requirements, the stated performance cannot be guaranteed.



Ventilation: Ensure adequate ventilation around the unit to prevent overheating. Allow at least 30 cm clearance from the ceiling to the top of the fermentation chamber.



Maximum Load: The maximum load for each wire shelf is 50kg. Total maximum load for the chamber is 150kg. Please make sure to empty all loads before moving the chamber.



Handling: Improper installation, maintenance or repair may put the user at considerable risk.



Cleaning or Service: Disconnect the unit from the power supply before cleaning or performing maintenance.



Ensure all operatives are aware the chamber contains a non-flammable gas that is toxic if inhaled in high concentrations. It exhibits an explosion risk if heated excessively.

Should a suspected leak become apparent, switch off the fermentation chamber and immediately evacuate the area.

3 Installation

3.1 Unpacking

Carefully remove the fermentation chamber from its packaging, including protective film and inspect for any damages. Use a pallet jack to lift and move the chamber away from the pallet. Pay attention to the instruction label at the bottom of the chamber for pallet jack. Only insert pallet jack into the sides of the chamber.

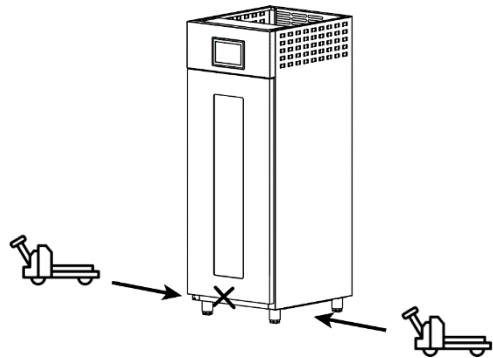

3.2 Placement

Place the unit on a flat, stable surface in a well-ventilated area. Rotate the Leg Sleeves to level the chamber in both left-to-right and front-to-rear directions. The wheels will be inaccessible once the sleeves are down.

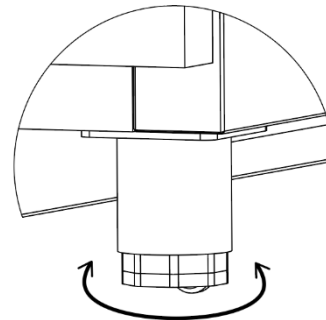

Caution: The height of the adjustable Legs must be within 10-13cm. The sleeve may come off if extended too much.

3.3 Duck bill grommet

Use the Duck bill grommet that is provided with the product and screw it underneath the chamber. The Duck bill grommet prevents temperature loss inside the chamber.

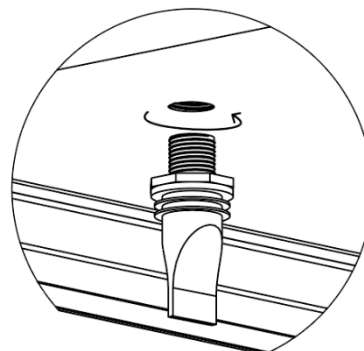

Alternative: It is possible to connect a water hose to the chamber with the L-shaped hose connector, to lead out water during cleaning.

3.4 Drip Pan

Slide the Drip Pan through the built-in tracks at the bottom of the chamber. Push it all the way in until it stops.

 **Attention:** Empty the Drip Pan regularly to prevent overflowing.

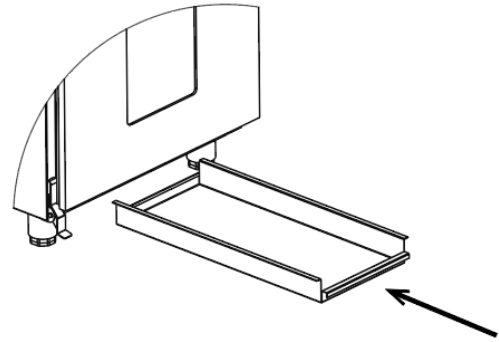

3.5 Door Opener *Add-On*

If Door Opener will be used, install it at this stage by following separate mounting instructions for the HakkoBako Door Opener.

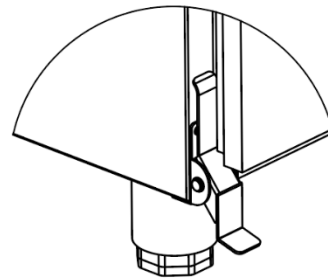

3.6 Wire Shelf and Shelf Brackets

To attach the Shelf Brackets, push the rail hooks down to fit into the square holes of the Shelf Posts (1). The shelf height is adjustable on 50mm intervals. To differentiate between left and right Shelf Brackets, the shelf stoppers are placed towards the rear end when mounted correctly (2). Once the Shelf Brackets are correctly mounted, slide in the Wire Shelves (3) with the large spokes giving weight support (4).

 **Attention:** Ensure sufficient gap for the air to flow through all ferments when loading the chamber. This is to allow optimal temperature distribution.

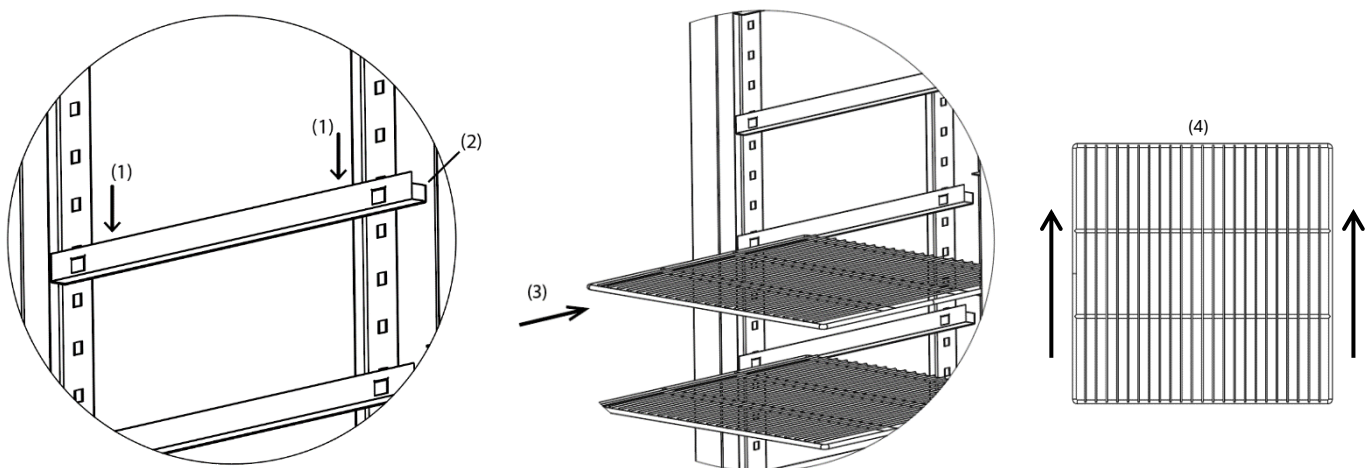

3.7 Electrical Connection

Connect the unit to a properly grounded electrical outlet.



Caution: Ensure the power voltage matches the unit's specifications.

3.8 Power On

Turn on the chamber using the power switch that is placed on the back side.

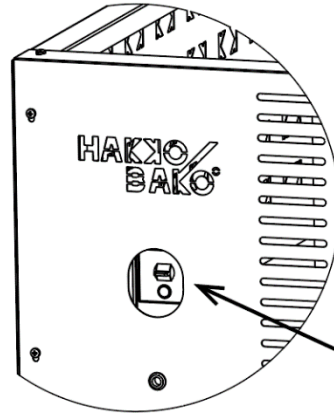

4 Operation

4.1 Setup the Chamber

1. **Power On:**

Please wait few minutes for the system to finish loading after the power is switched on.

2. **Access Settings:**

Press *Menu* icon  on the top left corner. Navigate to *Settings*

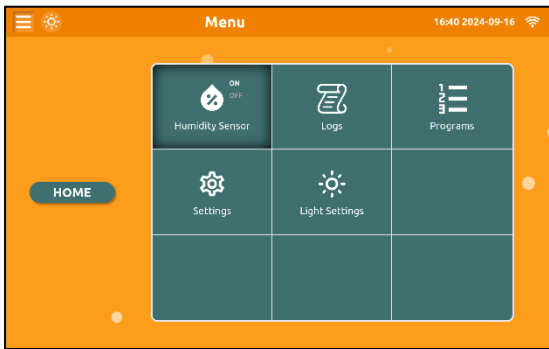

3. **Adjust Parameters:**

Adjust temperature unit and date formats (5), and set date and time as needed (6).



(5)

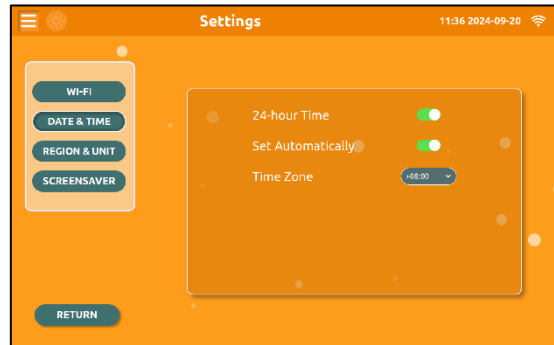

(6)



Attention: Please note that *Date & Time* settings is blocked when a program is running.

4. **Setup Wi-Fi:**

Press *Wi-Fi* from *Settings* and Connect to a secure Wi-Fi connection. Insert password if needed (7).



Attention: For public networks that require registration through a popup browser window – insert a physical computer keyboard into the USB slot, placed at the back of the electronics box to type in the correct login (8).



(7)

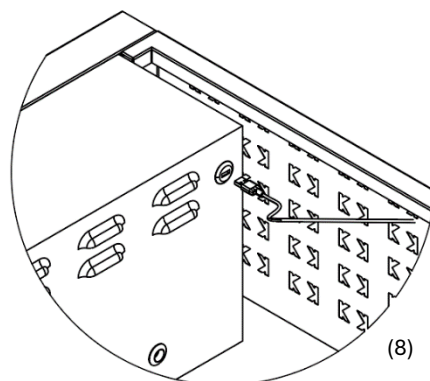

(8)

(8)

5. **Screensaver:**

To toggle ON the screensaver navigate to the settings menu and activate the screensaver option. Once it's enabled, you can select a preferred theme from the available options. The **waiting time** refers to the period of inactivity after which the screensaver will automatically appear on the screen. You can set this time according to your preference.

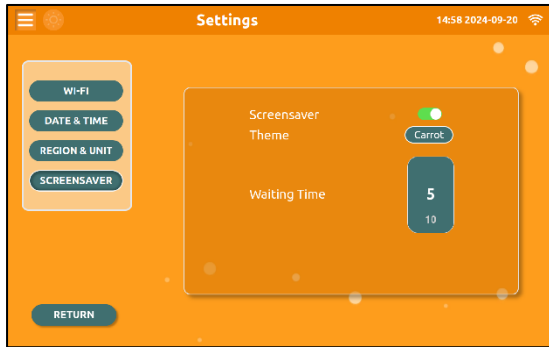

6. **Return to Home page:**

Press *Menu* icon  or press *Return* then *Home* to get back to main page. You are now ready to start a fermentation program.

4.2 Start New Program

4.2.1 Set Temperature

Slide the Temperature Bar to desired temperature. The temperature range is 2 to 60°C.

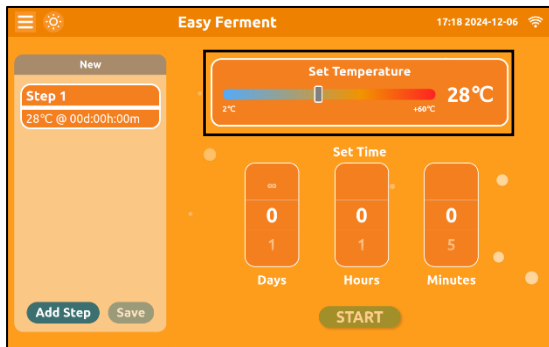

4.2.2 Set Time

Scroll the Time Wheels to desired days, hours and minutes for the chosen step.



Attention: It is possible to set to infinite time (∞) which can be found in the *Days* wheel.

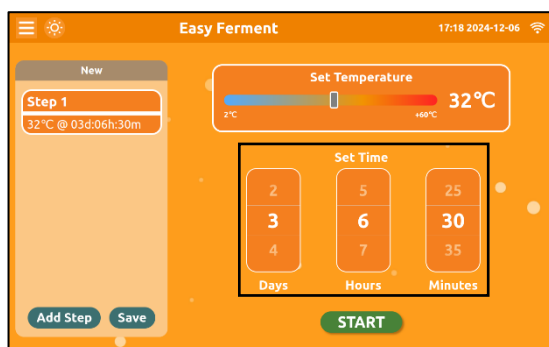

4.2.3 Add and remove steps

You can add up to 4 steps within one program. To remove a step, simply press the cross on the top right corner of the chosen step to delete it.

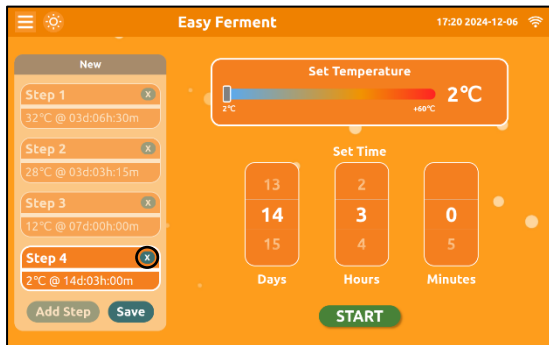

4.2.4 Save and Start



Once you are finished setting up the fermentation steps. Either press *Save* to only save your program or press *Start* to save and start the program.



4.2.5 Running

While a program is running, a white activity window will be visible at the status bar. The animated running icon  indicates that the chamber is running a program.

Progress Bar

As the program is running, the step progress bar shown in grey  indicates the current progress for the running step. The big progress bar  indicates the current progress for the whole program, visualized in both percentage and time.

Temperature and Humidity Graphs

The graphs provide visual status of the measured temperature and humidity.

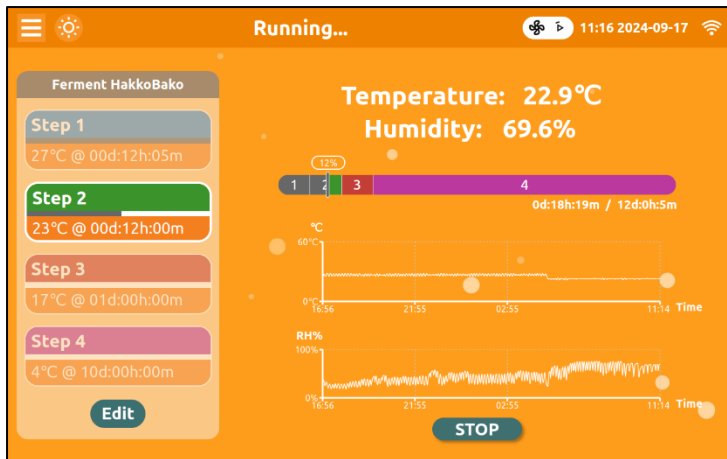





Edit & Stop Running Program

Press *Edit* to adjust temperature and time to desired new values.



Attention. Please note that it is not possible to delete or adjust the time of a current running step. It is possible to terminate the running program whenever it is needed by pressing *Stop*. A log will be automatically saved.

Activity Icons explained:

-  A program is running.
-  Fans are running. Please be aware that the fans keep running for few minutes after a program is stopped.
-  Heating is turned on.
-  Cooling is turned on.
-  Defrost program is running. This is a fully automated duty cycle that runs on intervals when the chamber is set to refrigeration.

4.3 Logs

4.3.1 Autosaved Logs & My Logs

From *Menu*, select *Logs*. *Autosaved* logs are all fermentation records that have been automatically saved from any ran programs (9). *My logs* are customized saved logs that are worth keeping (10). Choose an autosaved log and press *Save* to store it in *My Logs*.



Attention: The maximum amount of autosaved logs is 100. Older logs will be automatically deleted once the limit is reached. To remove a log, simply press the cross on the top right corner of the chosen log to delete it.

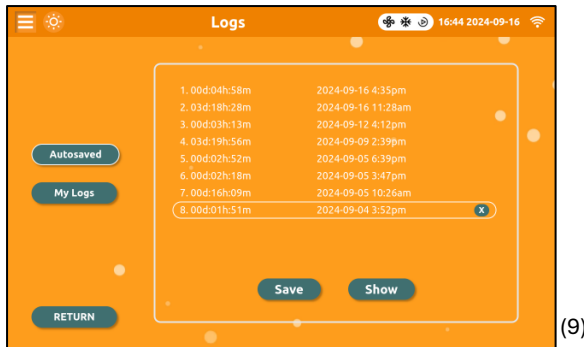

(9)

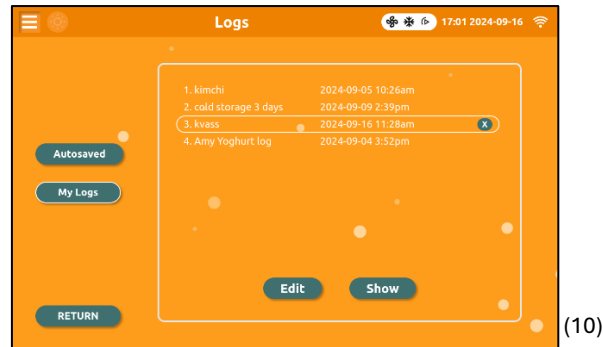

(10)

A log shows measured temperature and humidity over time. Click on any measured point in the graph to retrieve detailed information on measured temperature and humidity at a specific time.

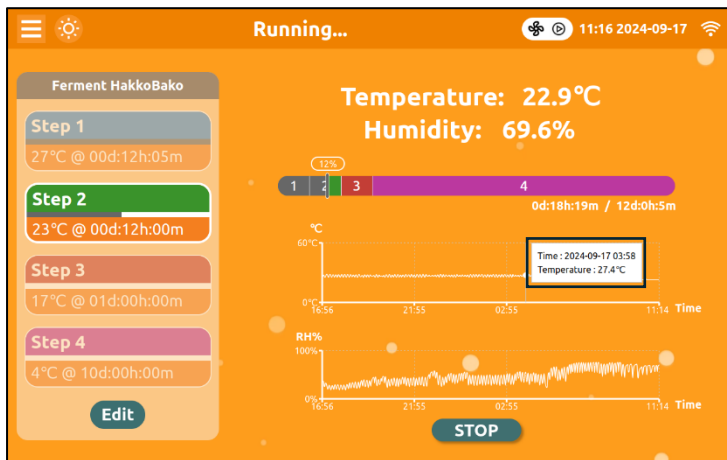

4.3.2 Exporting Logs

1. **Connect USB:** Insert a USB drive into the designated port, placed at the back of the electronics box.
2. **Export Data:** Select “Log” from the main menu and choose “Export” from either “Autosaved” or “My Logs” to transfer log data to the USB drive. Select the needed logs and press “Export” button.

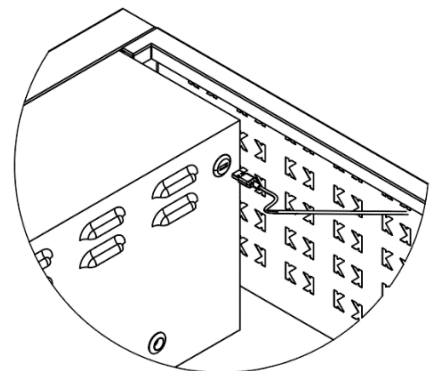

4.4 Program

4.4.1 New Program

From *Menu*, navigate to *Program* and select *New Program*. If a program is running, the system will ask if you want to cancel the current run. Follow the steps of [4.2.1](#) to [4.2.4](#) to set and run a program.

4.4.2 Load Program

From “Menu”, navigate to “Program” and select any pre-set program from the list. If a current program is running, the system will ask if you want to cancel the current run.

4.4.3 Edit and Save Program

A program can be edited and saved:

1. **Select Program:** Choose and load the program you wish to edit.
2. **Edit Parameters:** Once a program is loaded, adjust temperature, time and steps as needed.
3. **Save Program:** Save the changes as a new program by editing the name. If the name is not changed, the old program will be overwritten.

5 Maintenance

5.1 Cleaning

1. **Power Off:**

Turn off and unplug the unit before cleaning.

2. **Remove Components:**

Detach Wire Shelves, Rail Brackets and Shelf Posts for thorough cleaning. There are 3 screws fastened to each Shelf Post. Loosen them slightly with a screwdriver and push the Shelf Post upwards to unhinge it from the chamber wall.

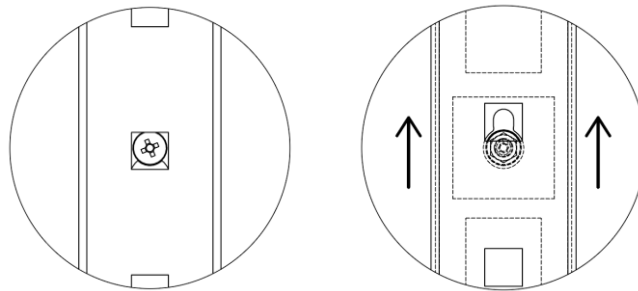

3. **Normal Cleaning:**

Wipe the interior and exterior with mild detergent and a damp cloth.

4. **Heavy Duty Cleaning:**

When necessary, detach the two Air Deflection Covers by removing all the screws. The Shelf Posts must be detached first before removing the Covers. Once the Air Deflection Covers are detached, it is possible to clean the back interior of the chamber, including the Air Circulation Fans, Evaporator and Heating Coils. Use warm water to rinse through the Evaporator and Heating Coils. The fins of the Evaporator are fragile and easy to bend – please avoid touching them.



Caution:

Make sure to let the Heating Coils cool down and Evaporator system to reach room temperature before cleaning the compartment. Do not touch the Heating Coils while they are still hot.

Attention:



- Use water and mild non-abrasive detergents when cleaning.
Do not use solvents and thinners.
- Do not splash water on the **Temperature Sensor** as it is not waterproof.
Use damp cloth instead.

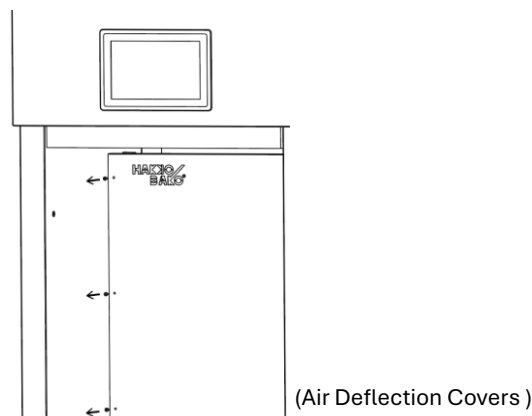

5. **Dry Thoroughly:** Ensure all components are dry before reassembling all the parts.

5.2 Shut Down

In normal conditions when the fermentation chamber is frequently used; keep it turned on. In case there is a need to shut down the unit:

1. **Complete Process:** When a fermentation programme is not completed, the system will continue once the machine is turned back on. Otherwise, stop the fermentation programme before shutting down the machine.
2. **Power Off:** Turn off the chamber using the power switch at the back of the machine.
3. **Unplug:** Disconnect the unit from the power supply.

5.3 Service and Parts Information

For service and replacement parts, contact the local distributor in your country [www.hakkobako.com/distributor] or HakkoBako customer service at [info@hakkobako.com].

5.3.1 Spare Parts Availability

The minimum period during which spare parts necessary for the repair of the appliance are available: 8 years.

Included Accessories

- 3 Heavy Duty Wire Shelves
- 8 sets Shelf Brackets

Check for more available parts and accessories on the website: [www.hakkobako.com]

5.4 Troubleshooting

Certain faults may occur during normal use of the chamber. In some cases, faults can be eliminated easily and quickly by following the Error Code List below.

The display shows a warning message or alarm describing the occurring fault.

If the fault persists, contact the Customer Service:

1. Switch off the safety circuit breaker of the chamber.
2. Disconnect the appliance from the main power supply.
3. Remember to specify:
 - the type of fault
 - the Product number code
 - the Serial number

5.4.1 Error Code List

Code	Problem and Possible Cause	Actions
E1b	Chamber overheated	Turn off the machine, open the door and let it cool down to room temperature before turning back on. If error persists, contact your service provider or an authorized HakkoBako service company.
E1c	Insufficient cooling 1) Door left open during refrigeration 2) Hot foods inside.	1) Make sure the door is closed. 2) Let hot food cool down to room temperature before placing it inside the chamber Restart the machine. If error persists, contact your service provider or an authorized HakkoBako service company.
E2b	Chamber too cold	Turn off the machine, open the door and let it warm up to room temperature before turning back on. If error persists, contact your service provider or an authorized HakkoBako service company.
E2c	Insufficient heating	1) Make sure the door is closed. 2) Defrost the food in incremental steps. Restart the machine. If error persists, contact your service provider or an authorized HakkoBako service company.
E3a	IO related (Hardware) error.	Restart the machine. If error persists, contact your service provider or an authorized HakkoBako service company

E3b	LED related (Hardware) error.	Restart the machine. If error persists, contact your service provider or an authorized HakkoBako service company.
E3c	Thermal sensor (Hardware) error.	Restart the machine. If error persists, contact your service provider or an authorized HakkoBako service company.
E4	Operating system error.	Restart the machine. If error persists, contact your service provider or an authorized HakkoBako service company.

6 Transport and Handling

- Personnel responsible for transport, handling, and storage of the device must have adequate training and practical experience in the safe use of lifting systems and personal protective equipment suitable for the tasks to be performed.
- Transport of the chamber must be done using special equipment with appropriate load capacity. Ensure the unit is securely packaged and upright during transport.
- Moving (i.e., shifting within the workplace) can be done by using the small Leg Wheels on smooth surfaces. Be careful not to toppling over the Chamber while moving. These wheels are not suitable for longer transportation and on rough surfaces.
- During loading and unloading, it is forbidden to stand under suspended loads.
- When lifting the machine, it is forbidden to anchor it to its movable or weak parts, such as covers, door or electrical conduits.
- Ensure that there is an appropriate area with a flat surface floor for unloading and storing the chamber.

7 Limited Warranty

HakkoBako offers a limited warranty of 1 year, effective from the date of installation. HakkoBako's liability under the terms of the warranty are limited and shall exclude routine servicing, cleaning, essential maintenance and/or repairs occasioned by misuse and installations not in accordance with HakkoBako guidelines.

Warranty does not include scheduled maintenance activities (including the parts required for it) or the supply of cleaning agents unless specifically covered within any local agreement, subject to local terms and conditions.

Warranty repairs should be completed by an approved HakkoBako dealer or service agency using genuine HakkoBako components.

The HakkoBako warranty does not cover:

- Service trips cost to deliver and pick up the product.
- Installation.
- Training on how to use/operate.
- Replacement (and/or supply) of wear and tear parts unless resulting from defects in materials or workmanship reported within one (1) week from the failure.
- Correction of external wiring.
- Correction of unauthorized repairs as well as any damages, failures and inefficiencies caused by and/or resulting from;
 - insufficient and/or abnormal capacity of the electrical systems (current/voltage/frequency, including spikes and/or outages).
 - plumbing parts, components or consumable cleaning products that are not approved by the manufacturer.
 - customer's negligence, misuse, abuse and/or non-compliance with the use and care instructions detailed within the appropriate equipment documentation.
 - improper or poor: installation, repair, maintenance (including tampering, modifications and repairs carried out by third parties not authorized) and modification of safety systems.
 - Use of non-original components (e. g.: consumables, wear and tear, or spare parts).
 - environment conditions provoking thermal (e. g. overheating/freezing) or chemical (e. g. corrosion/oxidation) stress.
 - foreign objects placed in- or connected to- the product.
 - accidents or force majeure.
 - transportation and handling, including scratches, dents, chips, and/or other damage to the finish of the product, unless such damage results from defects in materials or workmanship and is reported within one (1) week of delivery unless otherwise agreed.
- Product with original serial numbers that have been removed, altered or cannot be readily determined.
- Replacement of LEDs or any consumable parts.
- Any accessories and software not approved or specified by HakkoBako.

To obtain full details of your warranty and approved service agency, please contact your dealer/supplier, or email [info@hakkobako.com].

8 End-of-Life Disposal

Legislation varies from country to country. Follow the regulations and requirements of the country where the device is to be scrapped.

Before scrapping the device, carefully check its physical condition and whether any parts of the structure may collapse or break during dismantling.

The components of the device must be disposed of in different ways depending on their characteristics (i.e., metals, oils, grease, plastics, rubber, etc.). Remember that the compressor contains lubricating oil and refrigerant that can be recycled and reused, and the cooling system components are classified as special waste.

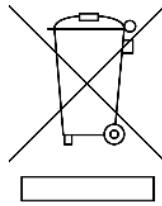

Operating Manual Rev1.5 - HakkoBako Pro Gen1 HBP01

Copyright 2024 Hakko Bako Limited

www.hakkobako.com